

<b>ZH</b> 用户手册 / 组装说明	<b>2</b>
<b>EN</b> Instructions for use / assembly instructions	<b>3</b>

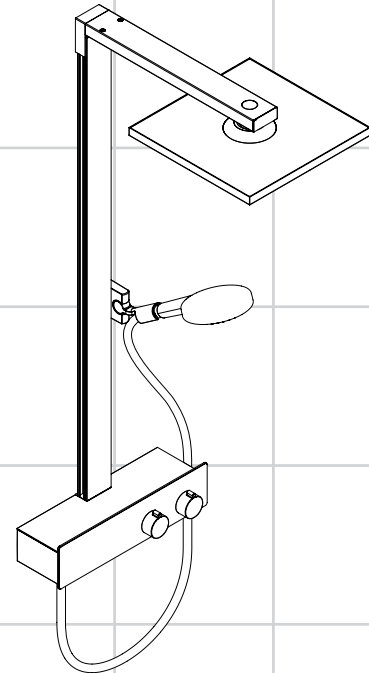

**Raindance E 300 1jet Showerpipe 350 ST EcoSmart**  
27362007

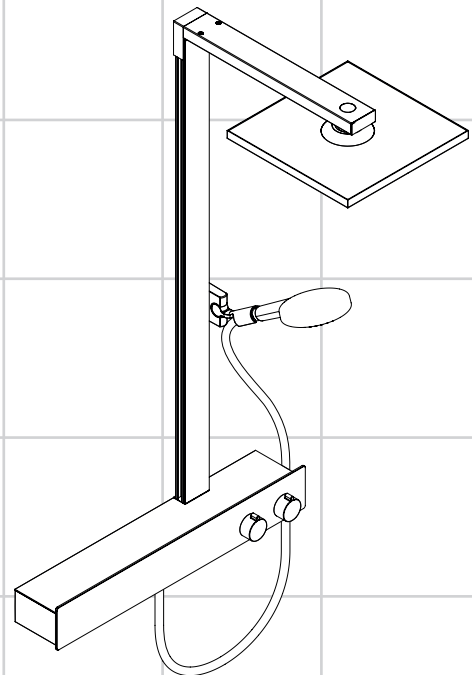

**Raindance E 300 1jet Showerpipe 600 ST EcoSmart**  
27364007



## 安全技巧

- △ 装配时为避免挤压和切割受伤，必须戴上手套。
- △ 本产品只允许作为洗浴、卫生和洁身之用。
- △ 头顶花洒夹持杆只为夹持头顶花洒而设计，不得让其承载其它物品！
- △ 不得让儿童和肢体、精神和/或意识有障碍的成人在不受监管的情况下使用淋浴系统。受酒精或毒品影响的人员不得使用淋浴系统。
- △ 必须避免让身体敏感部位（如眼睛）接触到莲蓬头喷水。必须保持莲蓬头与人头之间有充分的距离。
- △ 该产品不得作扶柄使用。必须安装单独的扶柄。
- △ 冷热水管间过大的压力差必须予以平衡。

## 安装提示

- 安装前必须检查产品是否受到运输损害。安装后将不认可运输损害或表面损伤。
- 管道和阀门必须根据通用标准进行安装、冲洗和检查。
- 请遵守当地国家现行的安装规定。
- 本安装说明中所规定的安装尺寸理想用于身高 1700 mm 左右的人士。尺寸可根据需要进行修改。在这种情况下，您必须留意，如果安装高度改变，则花洒到地板的最小高度也随之改变，且必须考虑到连接尺寸的改变。
- 由有资格的专业人员进行产品安装时请注意：在所有加固区域中，加固表面是否平整（无突出的接缝或瓷砖），墙体结构是否适合产品安装且未显露出任何缺点。
- 必须装上花洒所附带的滤网密封垫，以过滤管道里的杂质污物。杂质污物会影响花洒的功能和/或损坏花洒的功能部件，由此而产生的产品损坏不属于汉斯格雅的保修范围。
- 本产品并非设计来与蒸气浴连接使用！

## 技术参数

工作压强:	最大 1 MPa
推荐工作压强:	0,15 - 0,5 MPa
测试压强:	1,6 MPa
(1 MPa = 10 bar = 147 PSI)	
热水温度:	最大 70°C
推荐热水温度:	65°C
中心距离:	150 ± 12mm
连接管线G 1/2:	左热右冷
热力消毒:	最大 70°C / 4 分钟
自动防止回流	
该产品专为饮用水设计！	

## 符号说明



请勿使用含有乙酸的硅胶！

**max.**  
**≈ 42°C**

### 安全功能 (参见第页 7)

恒温阀芯的安全功能可以预先设定所希望的最高出水温度，例如最高温度为42°C



### 校准 (参见第页 6)

安装完成后必须检查调温器的出水温度。如在取水处测量所得的温度与调温器上设定的温度有偏差，那么必须进行调整。



### 保养

- 此恒温龙头带有单向阀。单向阀必须在符合国家或当地法律的情况下按照DIN EN 1717定期检查（至少一年一次）。
- 为了保证恒温器的稳定运转，请务必定期从最热到最冷转动调温器。



### 大小 (参见第页 10)

### 流量示意图 (参见第页 10)

- ① 手持花洒
- ② 顶置花洒



### 操作 (参见第页 8)

请在使用喷头后略微倾斜，排空其中水分。



### 清洗 (参见第页 11)



### 备用零件 (参见第页 14)

### 选装附件 (不在供货范围内)

匹配瓷砖的圆盘 镀铬 #93146000 (参见第页 14)





## Safety Notes

- ⚠ Gloves should be worn during installation to prevent crushing and cutting injuries.
- ⚠ The product may only be used for bathing, hygienic and body cleaning purposes.
- ⚠ The arm of the shower head is intended only to hold the shower head. Do not load it down with other objects!
- ⚠ Children as well as adults with physical, mental and/or sensoric impairments must not use this product without proper supervision. Persons under the influence of alcohol or drugs are prohibited from using this product.
- ⚠ Do not allow the streams of the shower touch sensitive body parts (such as your eyes). An adequate distance must be kept between the shower and you.
- ⚠ The product may not be used as a holding handle. A separate handle must be installed.
- ⚠ The hot and cold supplies must be of equal pressures.

## Installation Instructions

- Prior to installation, inspect the product for transport damages. After it has been installed, no transport or surface damage will be honoured.
- The pipes and the fixture must be installed, flushed and tested as per the applicable standards.
- The plumbing codes applicable in the respective countries must be observed.
- The installation dimensions stated in these installation instructions are ideal for people of approximately 1700 mm in body height. The dimensions can be altered if required. In this case, pay attention to the fact that a change of installation height will also change the minimum height, and that the altered mounting dimensions must be taken into consideration.
- During installation of the product by qualified trained personnel, make sure that the entire fastening surface is even and smooth (no protruding seams or tile offset), that the finish of the wall is suitable to apply the product and has no weak points.
- The mesh washer must be insert to protect the overhead shower against incoming dirt by pipework. Incoming dirt leads to defects or/and can damage parts of the shower; such caused faults voids all liability and guarantee claims.
- The product is not designed to be used with steam baths!

## Technical Data

Operating pressure:	max. 1 MPa
Recommended operating pressure:	0,15 - 0,5 MPa
Test pressure:	1,6 MPa
(1 MPa = 10 bar = 147 PSI)	
Hot water temperature:	max. 70 °C
Recommended hot water temp.:	65 °C
Centre distance:	150±12mm
Connections G 1/2:	cold right - hot left
Thermal disinfection:	max. 70 °C / 4 min

### Safety against backflow

The product is exclusively designed for drinking water!

## Symbol description



Do not use silicone containing acetic acid!

## max. Safety Function (see page 7)

≈ 42 °C

The desired maximum temperature for example max. 42° C can be pre-set thanks to the safety function.



## Adjustment (see page 6)

After the installation, the output temperature of the thermostat must be checked. A correction is necessary if the temperature measured at the output differs from the temperature set on the thermostat.



## Maintenance

- The mixer is equipped with check valves. The check valves must be checked regularly according to DIN EN 1717 in accordance with national or regional regulations (at least once a year).
- To guarantee the smooth running of the thermostat, it is necessary from time to time to turn the thermostat from total hot to total cold.



## Dimensions (see page 10)



## Flow diagram (see page 10)

- ① Hand shower
- ② overhead shower



## Operation (see page 8)

To empty the overhead shower after use, hold it in a slightly inclined position.



## Cleaning (see page 11)



## Spare parts (see page 14)



## Special accessories (order as an extra)

tile-matching-disk chrome plated #93146000 (see page 14)



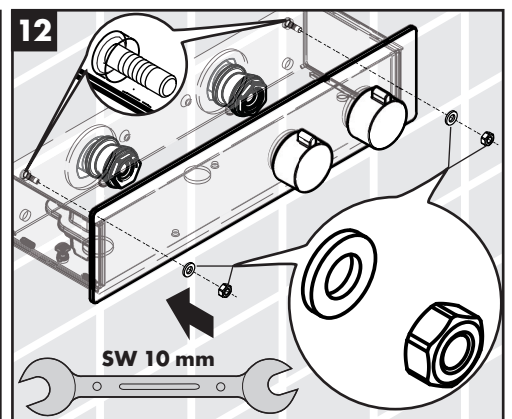
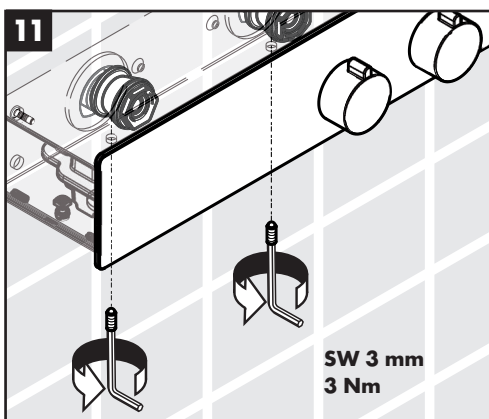
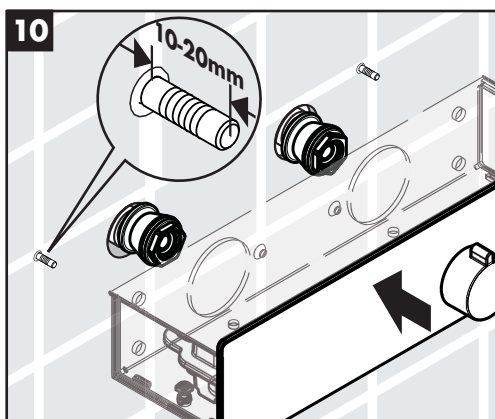
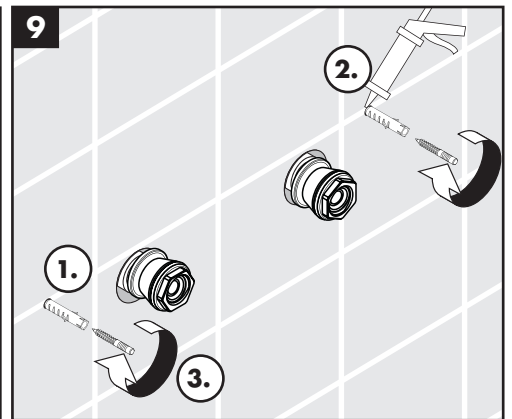
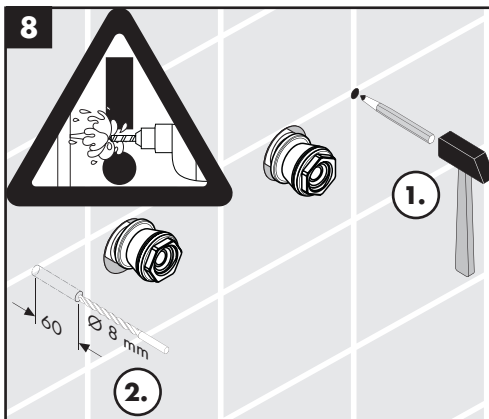
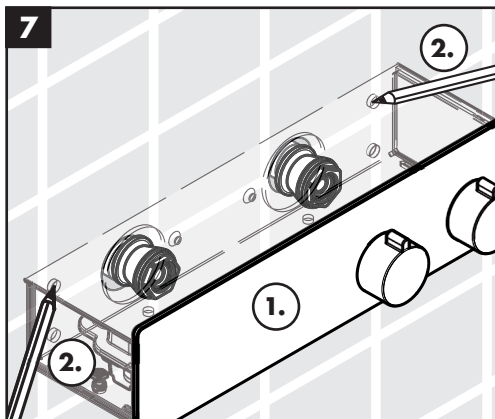
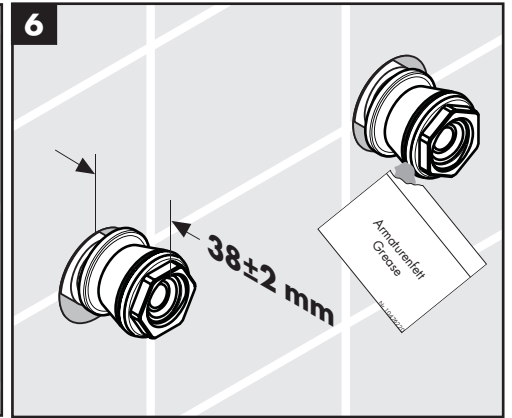
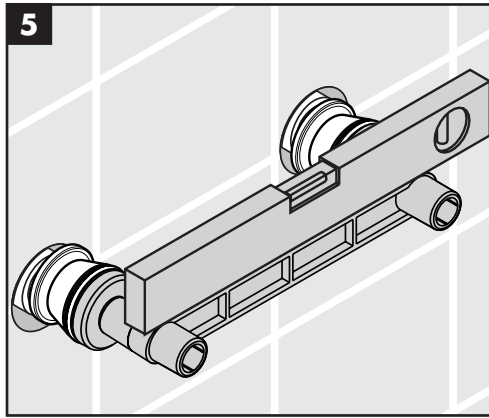
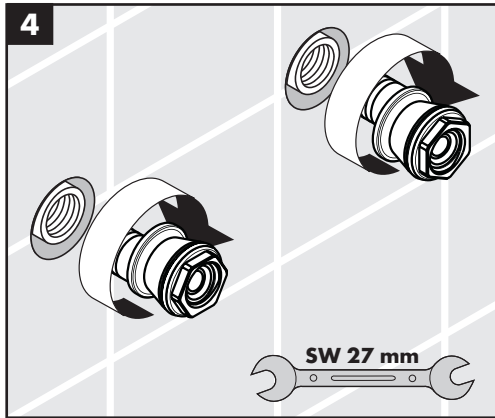
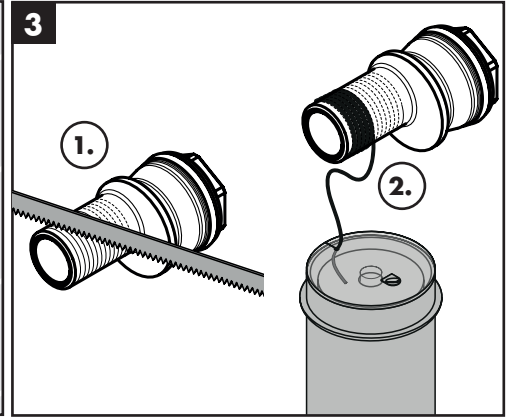
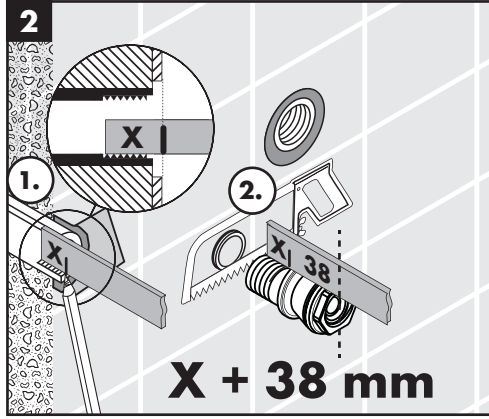
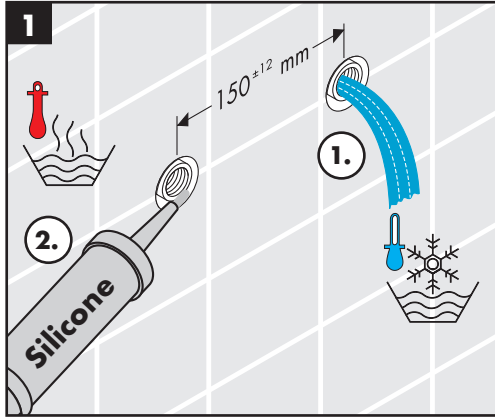

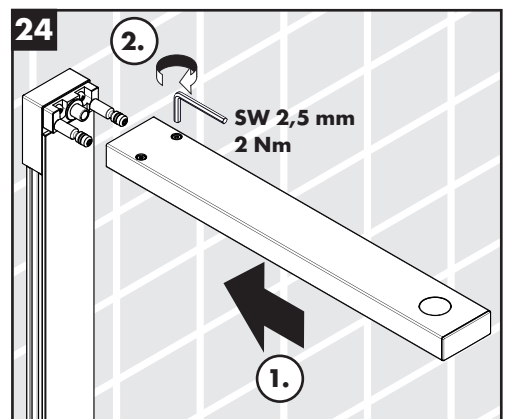
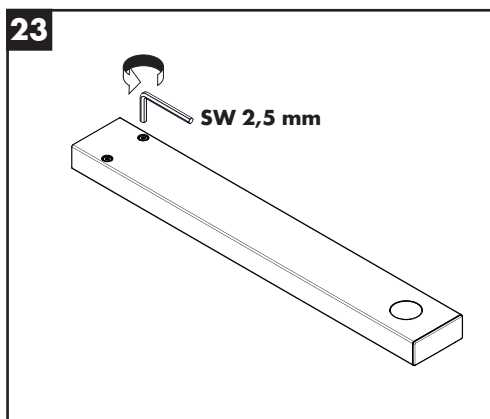
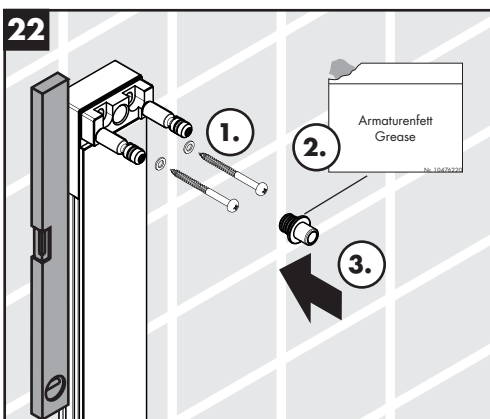
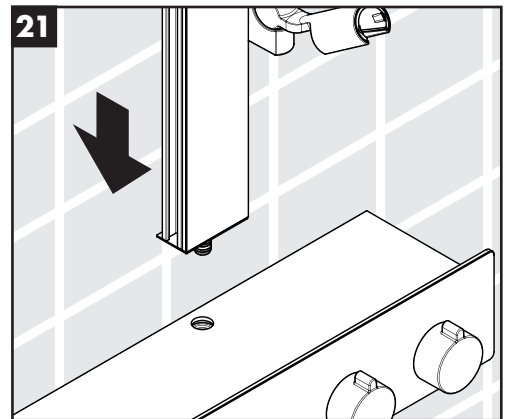
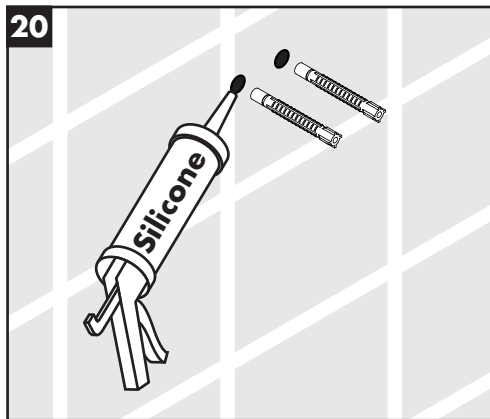
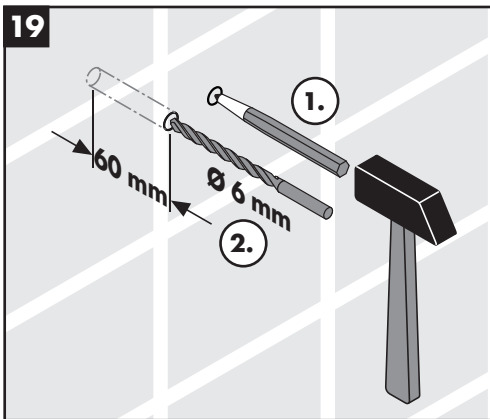
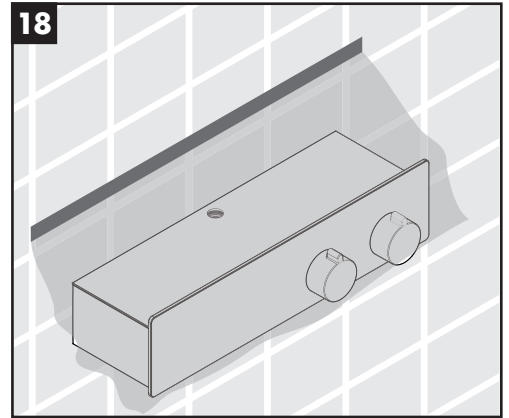
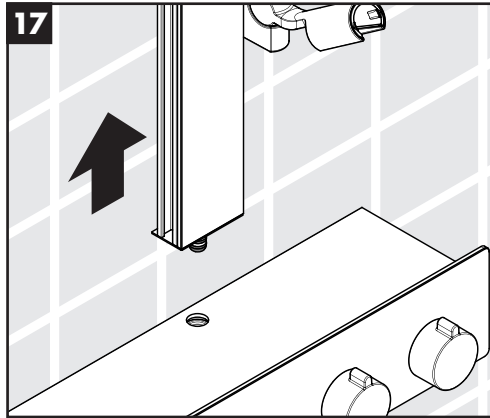
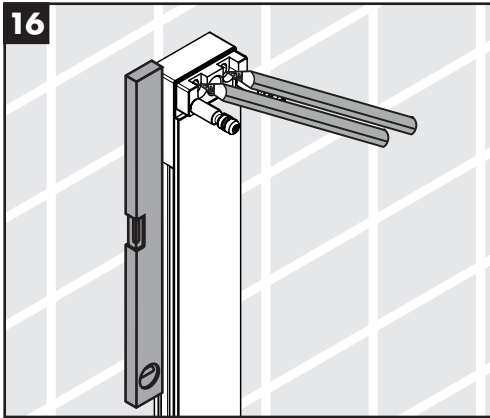
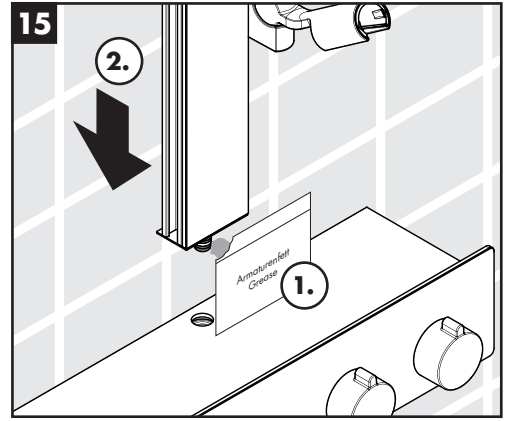
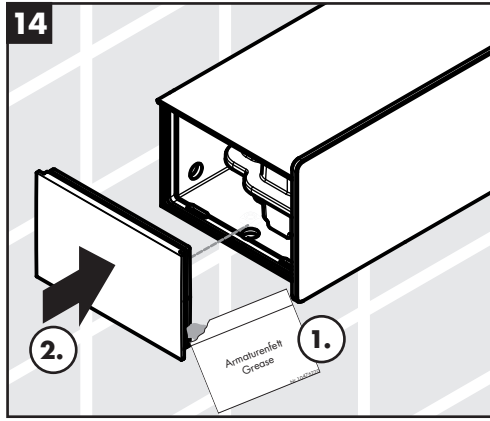
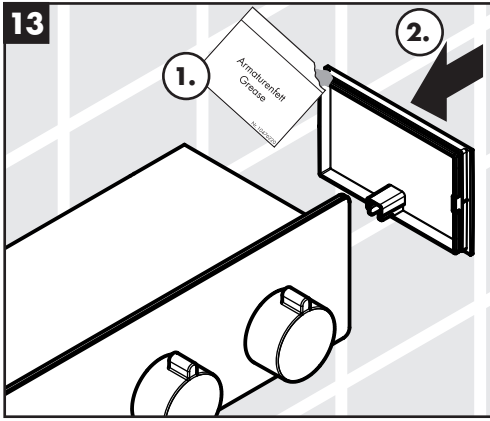

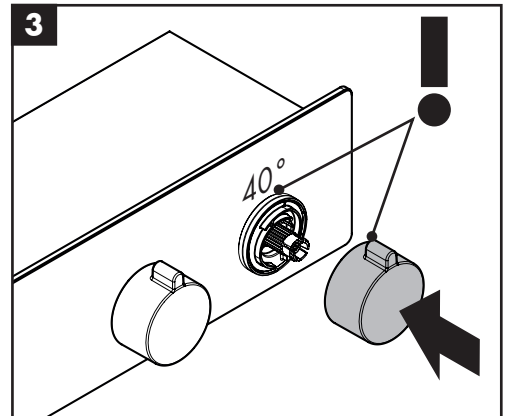
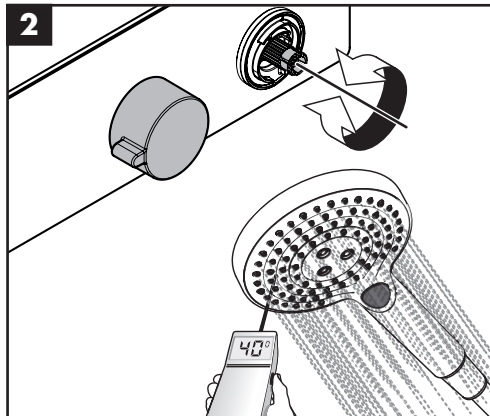
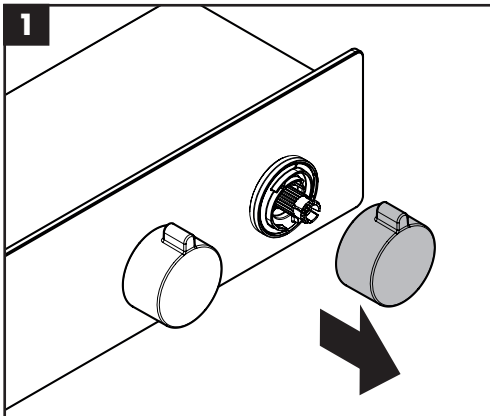
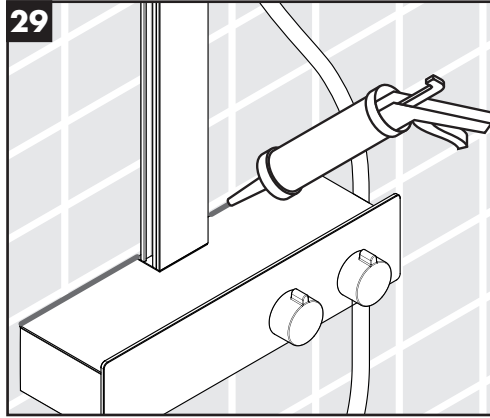
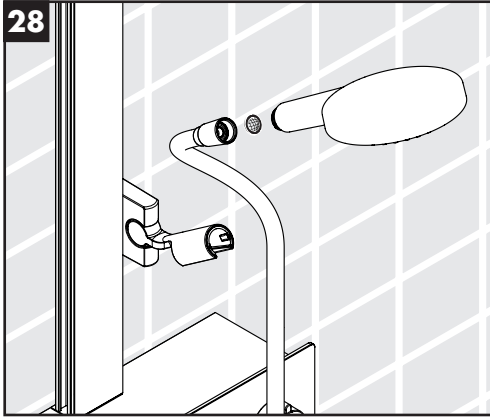
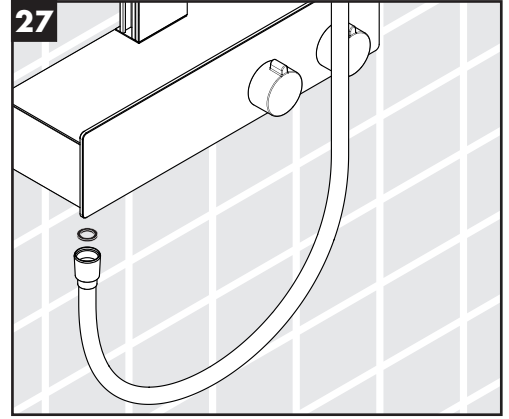
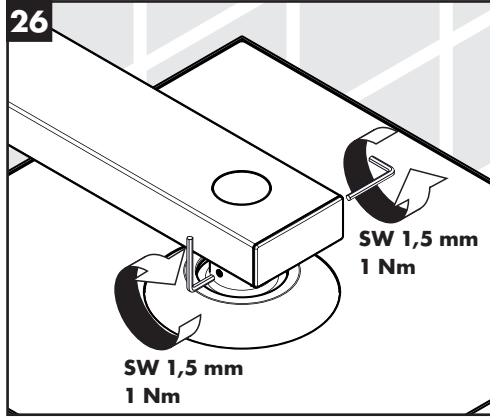
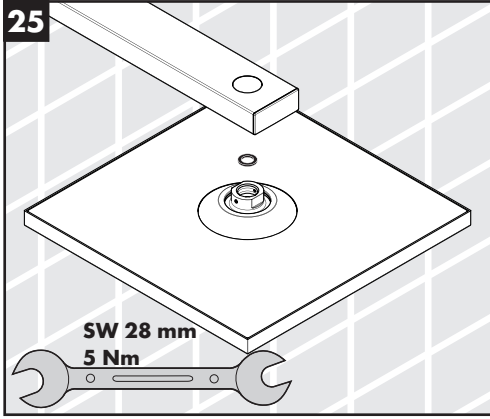

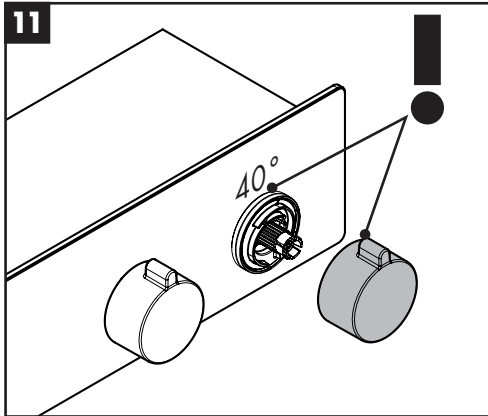
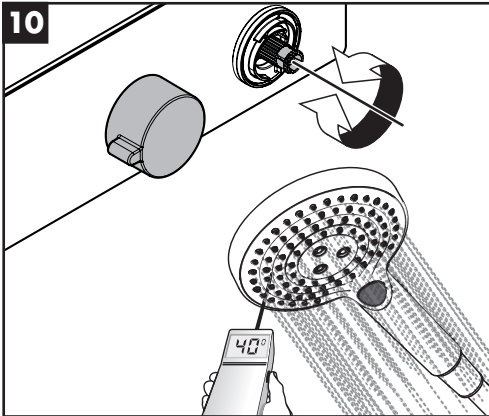
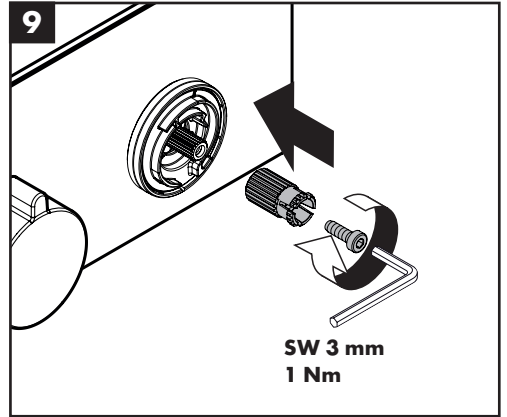
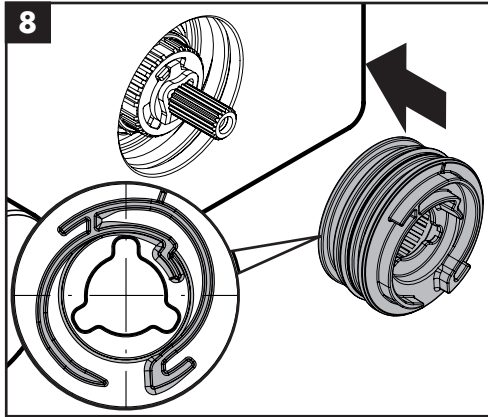
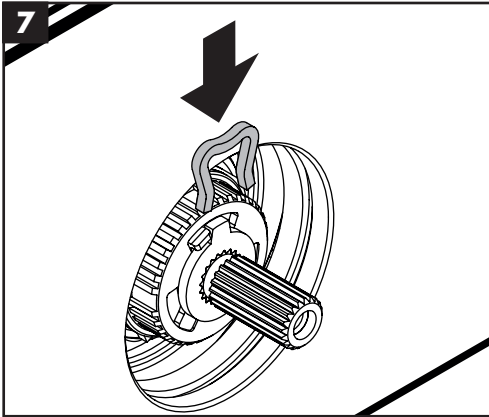
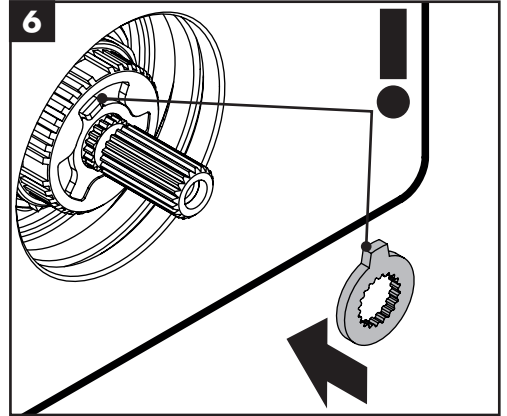
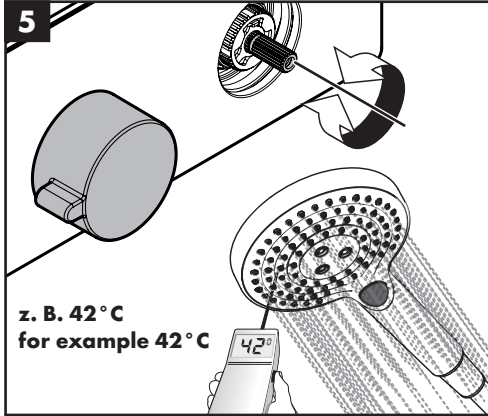
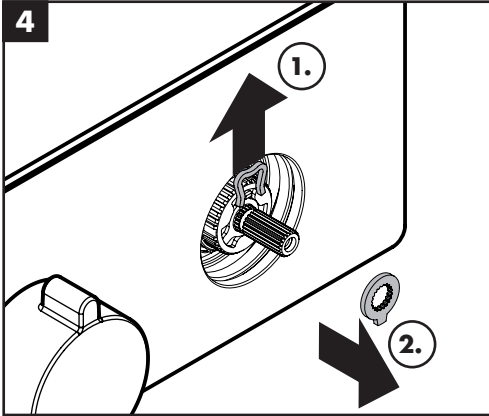
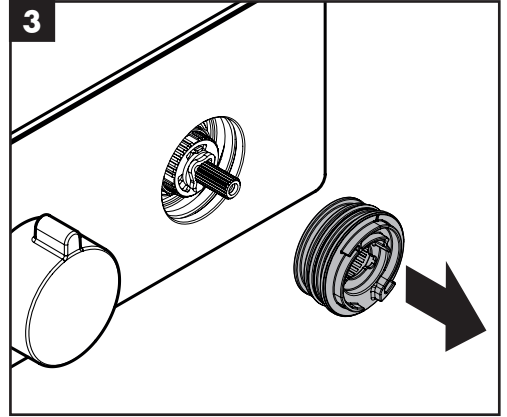
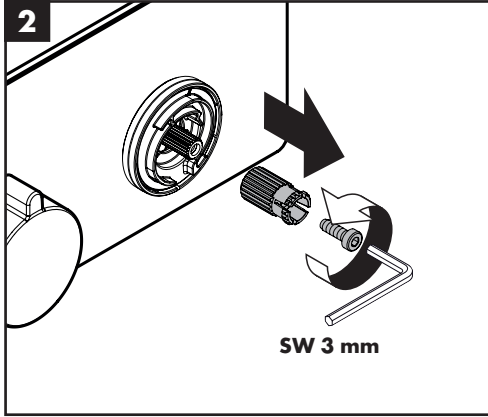
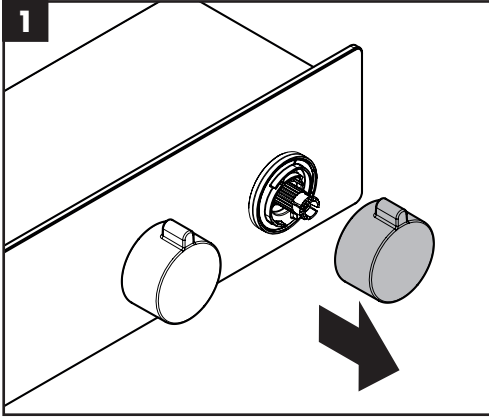

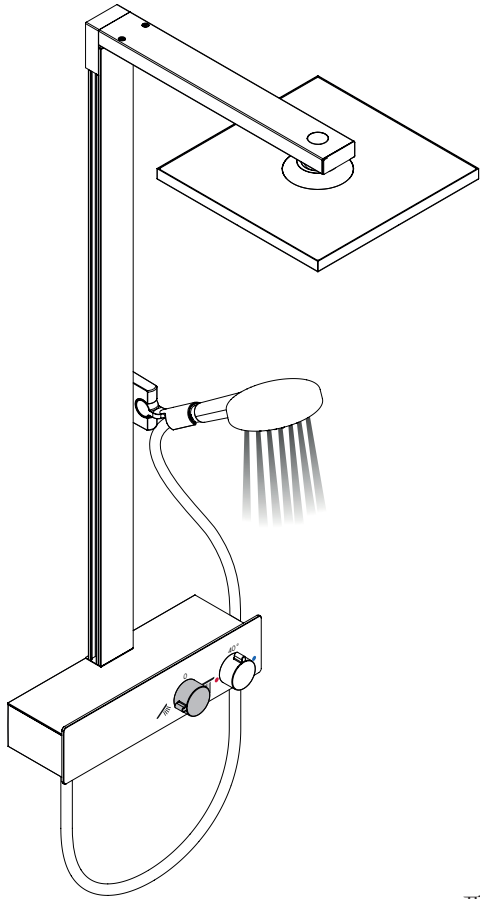

开 / open

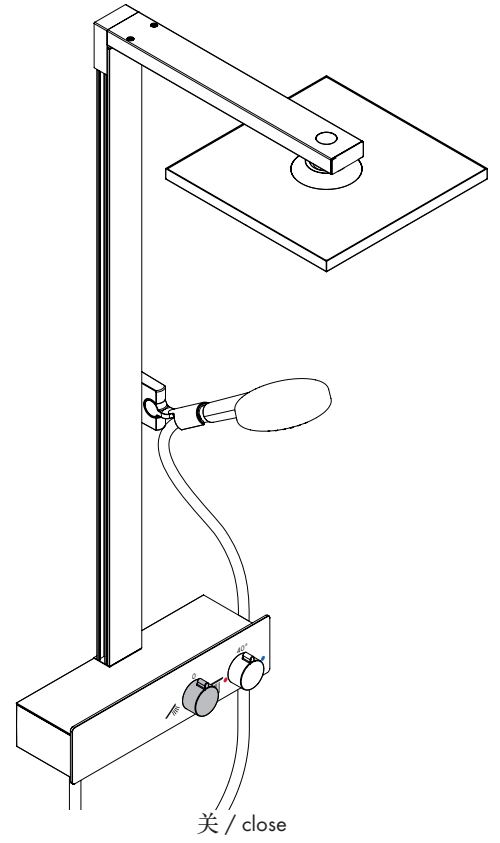
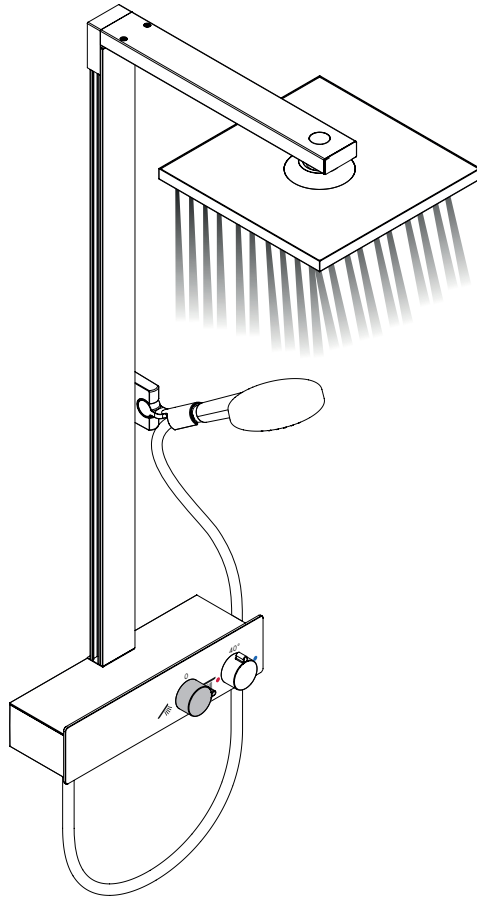

关 / close

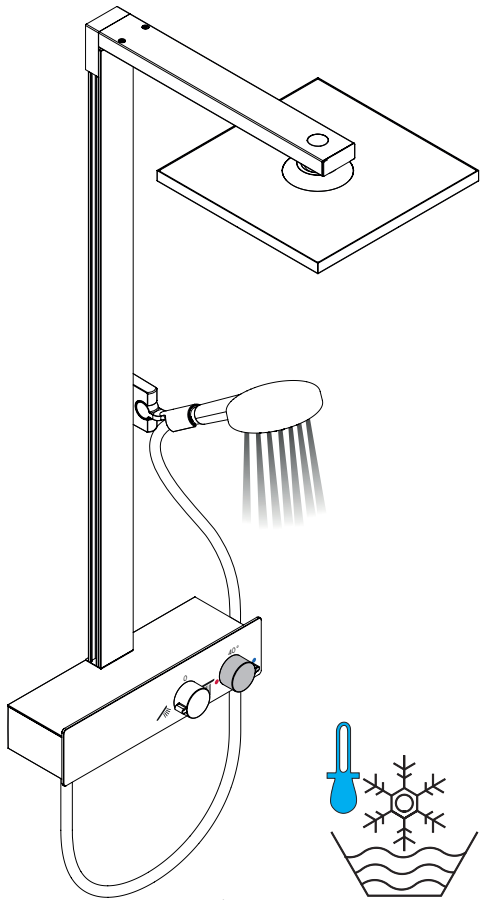

冷 / cold

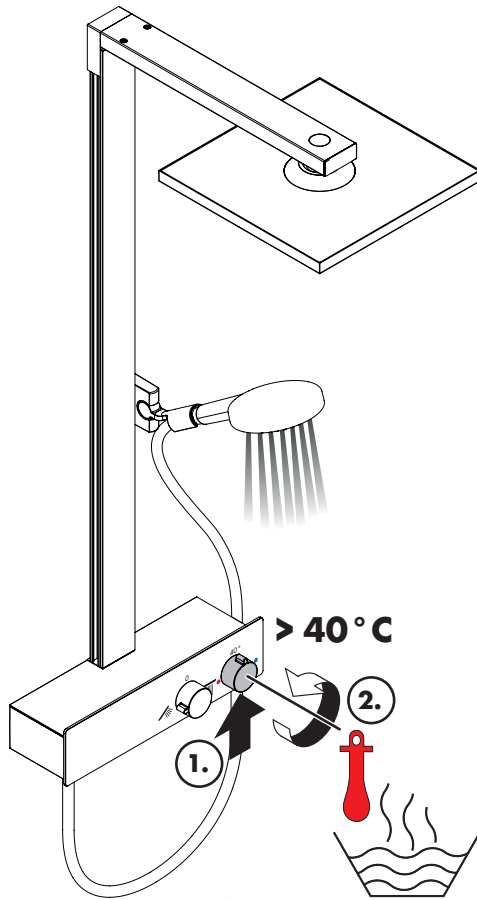

热 / hot

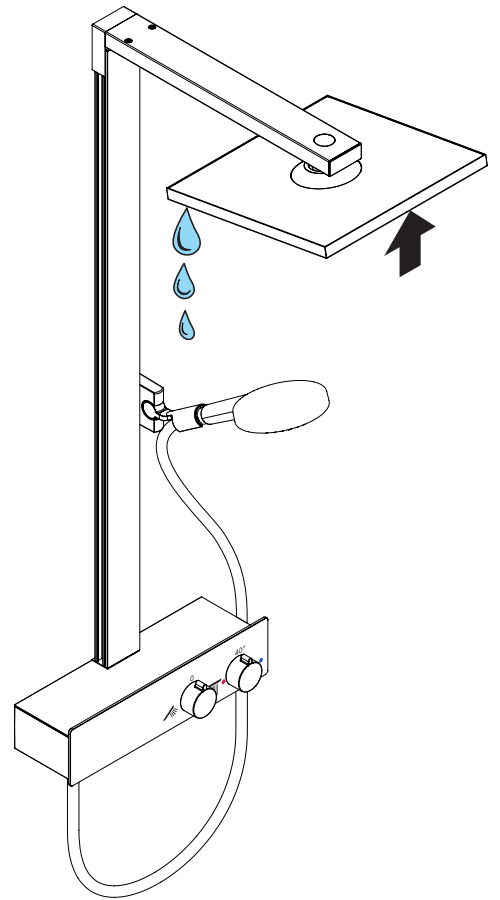



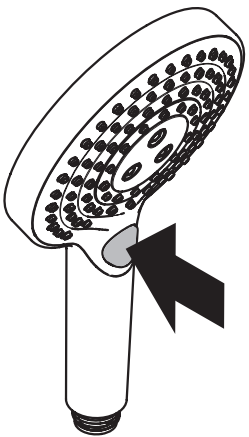
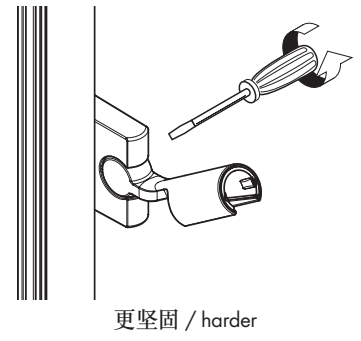
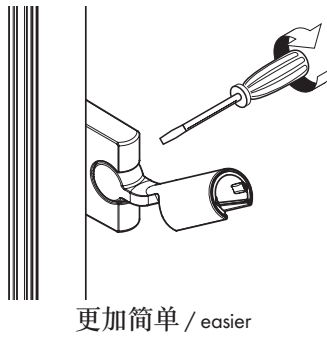
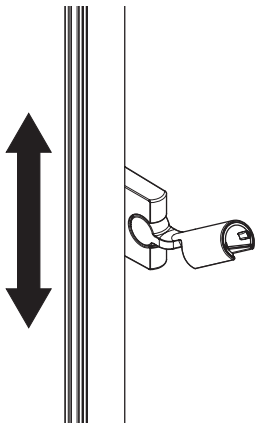
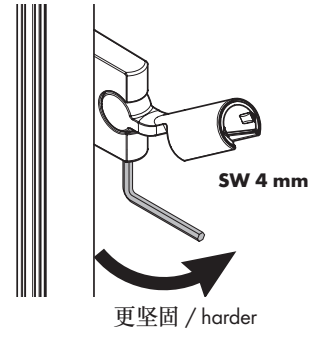
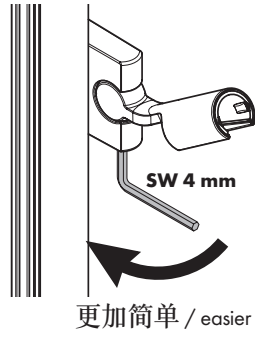
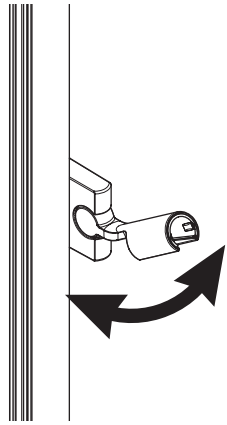





## 汉斯格雅产品的清洁建议

现代的卫浴龙头、厨房龙头、花洒、配件、盥洗台、浴盆和加热器采用的制造材料非常迥异，以适应产品外形设计和使用功能的市场需求。

为了避免产品损坏和由此引发的投诉及争议，必须在使用和清洁产品时遵循有关规程。

在保养汉斯格雅产品时，原则上必须注意：

- 只能使用那些有明确注明是适用于本产品的清洁剂。
- 不允许使用含有盐酸、蚁酸、氯漂或醋酸的清洁剂，因为这些清洁剂会给产品表面造成严重的损伤。
- 含磷酸的清洁剂必须在特定条件下使用。
- 不允许将两种以上清洁剂混合使用。
- 不允许使用具有研磨作用的清洁工具和设备，如不适合的清洁粉末、海绵垫或超细麦克布。
- 必须严格遵守清洁剂生产厂商的使用说明。
- 严格遵守清洁剂的用量和作用时间，决不允许清洁剂的作用时间长于规定值。
- 定期的清洁以预防水垢。
- 不允许将清洁剂直接喷射到汉斯格雅产品上，因为喷雾会进入汉斯格雅产品的开口部分和缝隙中而造成损害。首先将清洁剂喷在软布上，再用软布进行清洁。
- 清洁之后必须用足够的水冲洗，以彻底去除残留的吸附物（清洁剂）。
- 不允许使用蒸汽清洗机，高温会损害产品。

### 重要说明

肥皂、洗发水、沐浴液、染发剂、香水、刮胡水、指甲油的残留也会对产品造成损伤。

此处：使用后要小心地用清水将剩余物冲洗干净。

同样在产品下方不得存放洗涤剂和化学药品，例如不可放在用于洗脸盆的梳洗柜中否则挥发气体将损坏产品。

在已经损伤的表面继续使用清洁剂会给表面造成更大的损伤。



表面损坏的部件必须更换，否则会有受伤的危险。

不按规定进行清洁而造成的任何损坏不在本公司产品保修范围之内。

### QuickClean

有了QuickClean，手工清洁功能，要去掉喷头上的水垢，只需简单地搓除即可。

### 担保

Hansgrohe 向用户保证，该产品无制造缺陷。如果自购买之日起五年内出现缺陷，Hansgrohe 将免费排除。保证条件和详情见 [www.hansgrohe-int.com/guarantee](http://www.hansgrohe-int.com/guarantee)。在提出保修的权利时请联系您的合同方。本保证不涉及有关国家法律规定的消费权

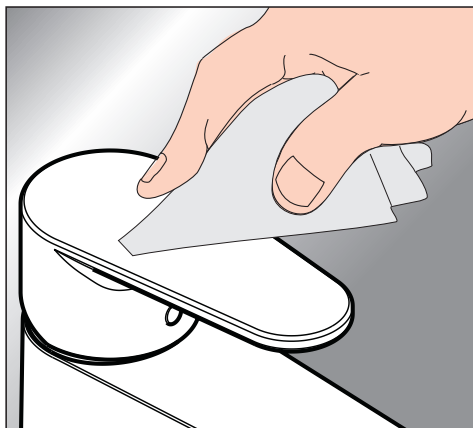

## Cleaning Recommendation for Hansgrohe Products

Today, modern sanitary and kitchen tapware, showers, accessories, washstands, tubs and radiators consist of very different materials to comply with the needs of the market with regard to design and functionality.

To avoid damage and reclamations, it is necessary to consider certain criteria when cleaning.

**With regard to caring for the Hansgrohe products, the following must in principle be heeded:**

- Only use cleaning material which is explicitly provided for this type of application.
- Never use cleaning materials, which contain hydrochloric acid, formic acid, chlorine pale lye or acetic acid, as they cause considerable damage.
- Phosphorus acidic cleaners are only conditionally applicable.
- Mixing cleaning agents is not permitted, generally.
- Never use cleaning materials or appliances with an abrasive effect, such as unsuitable cleaning powders, sponge pads or micro fibre cloths.
- The instructions of the cleaning agent manufacturers have to be followed absolutely.
- Cleaning has to be carried out with a specified cleaner dosage, contact time, object-related and adapted to the needs.
- The building up of calcifications has to be removed by cleaning regularly.
- When using spray cleaners, spray the cleaning solution onto a soft cloth or sponge, never directly onto the Hansgrohe products, as the atomised spray could enter openings and gaps in the Hansgrohe products and cause damage.
- After cleaning rinse thoroughly with clean water to remove any cleaner residue.
- The use of steam cleaners is not permitted. The high temperatures can damage the products.

### Important

Residues of toiletries such as liquid soaps, shampoos and shower gels, hair dyes, perfumes, aftershave and nail varnish can also cause damage.

Here too: Carefully rinse with water after use to remove residues.

Likewise, do not store any cleaning agents or chemicals under the products, for example in a vanity unit, as the vapours may damage the products.

The damage of already damaged surfaces will deteriorate under the effect of the cleansers.



**Components with damaged surfaces must be exchanged, otherwise there could be an injury danger.**

Damage caused by improper treatment will not be covered by our guarantee.

### QuickClean

The QuickClean cleaning function only needs a small manual rub over to remove the lime scale from the spray channels.

### Warranty

Hansgrohe guarantees to the consumer that this product is free of production faults. If nevertheless any defect is detected within 5 years from date of purchase, Hansgrohe will remedy this defect free of charge. You will find the conditions and details of this guarantee at [www.hansgrohe-int.com/guarantee](http://www.hansgrohe-int.com/guarantee). Please contact your contracting party to claim your rights under this guarantee. This guarantee does not affect the customer's rights under the respective national legislation.

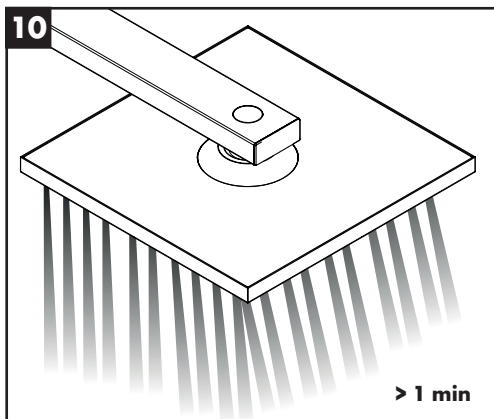
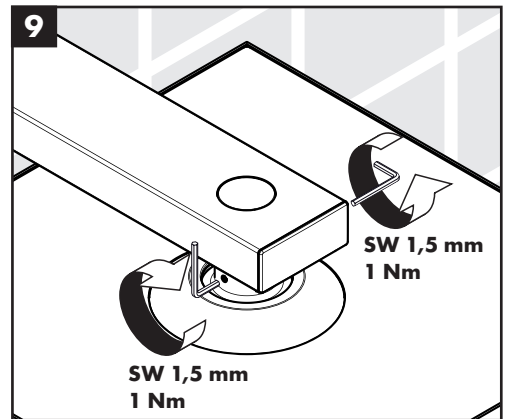
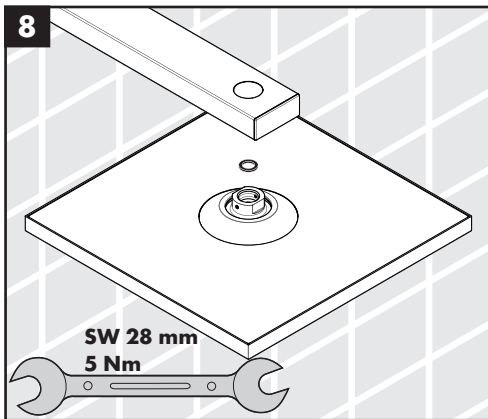
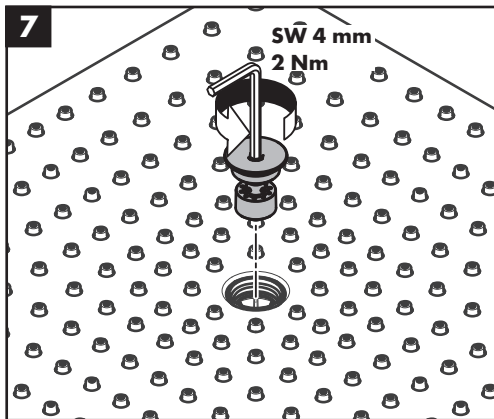
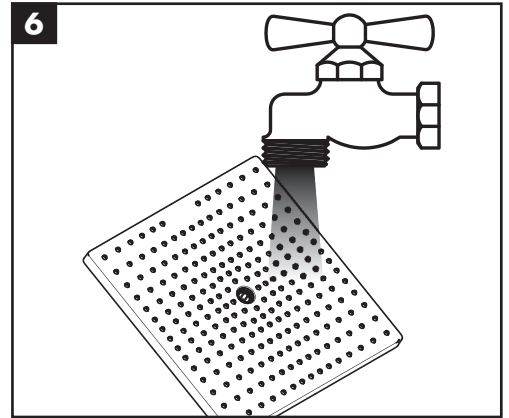
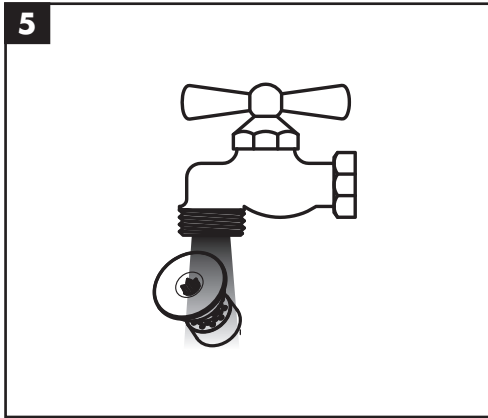
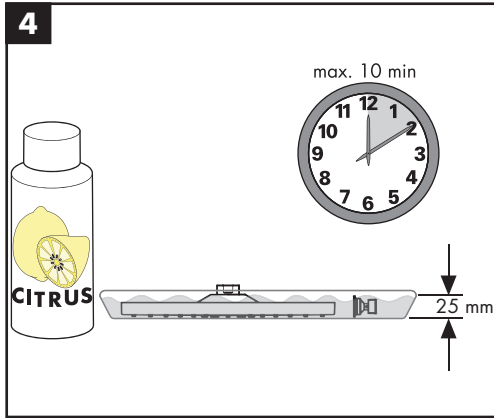
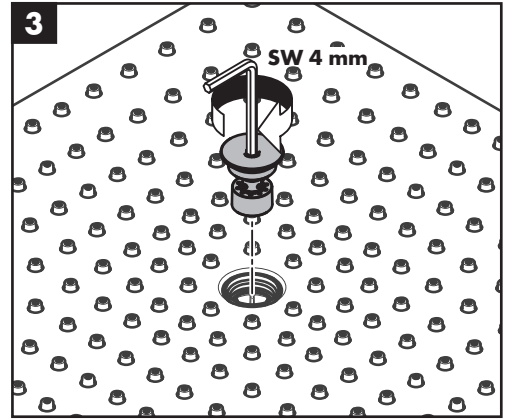
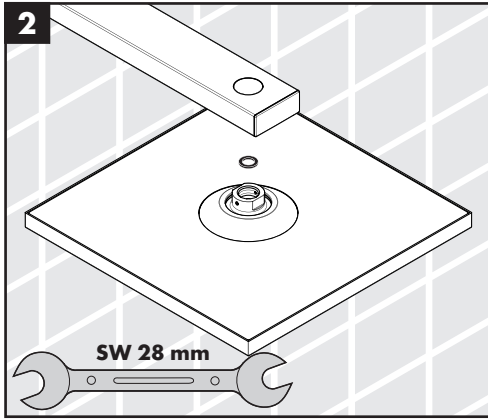
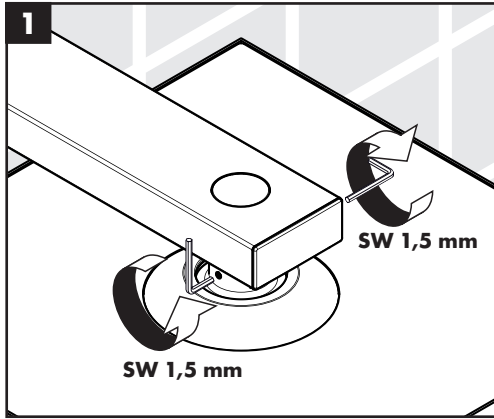
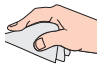

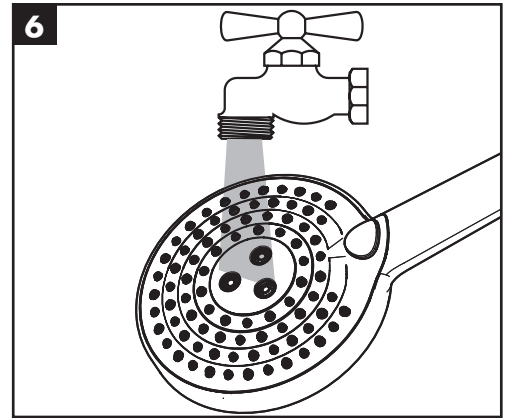
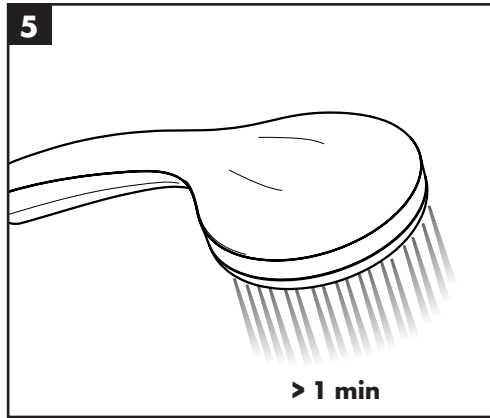
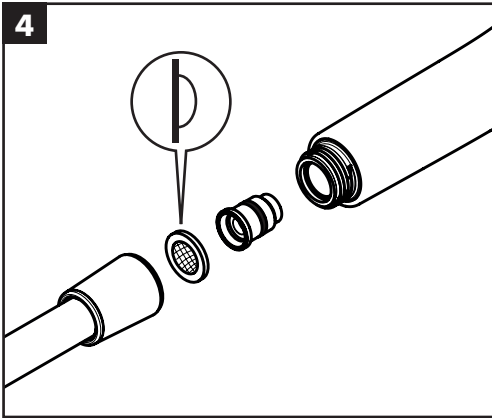
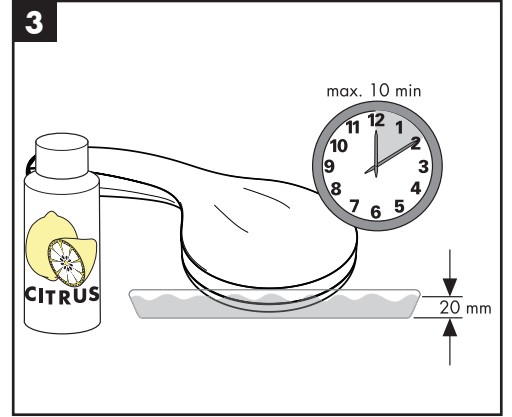
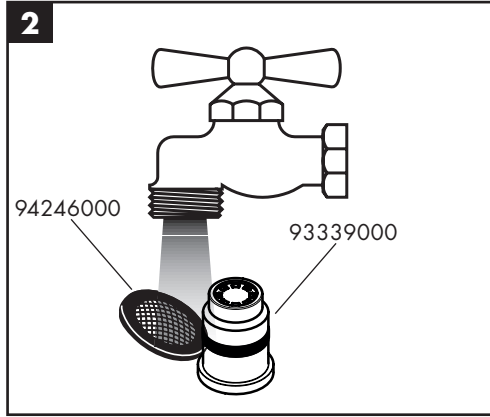
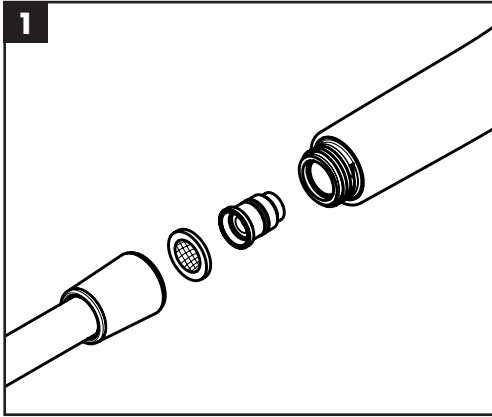



**Raindance E 300 1jet Showerpipe 350 ST EcoSmart 27362007**  
**Raindance E 300 1jet Showerpipe 600 ST EcoSmart 27364007**

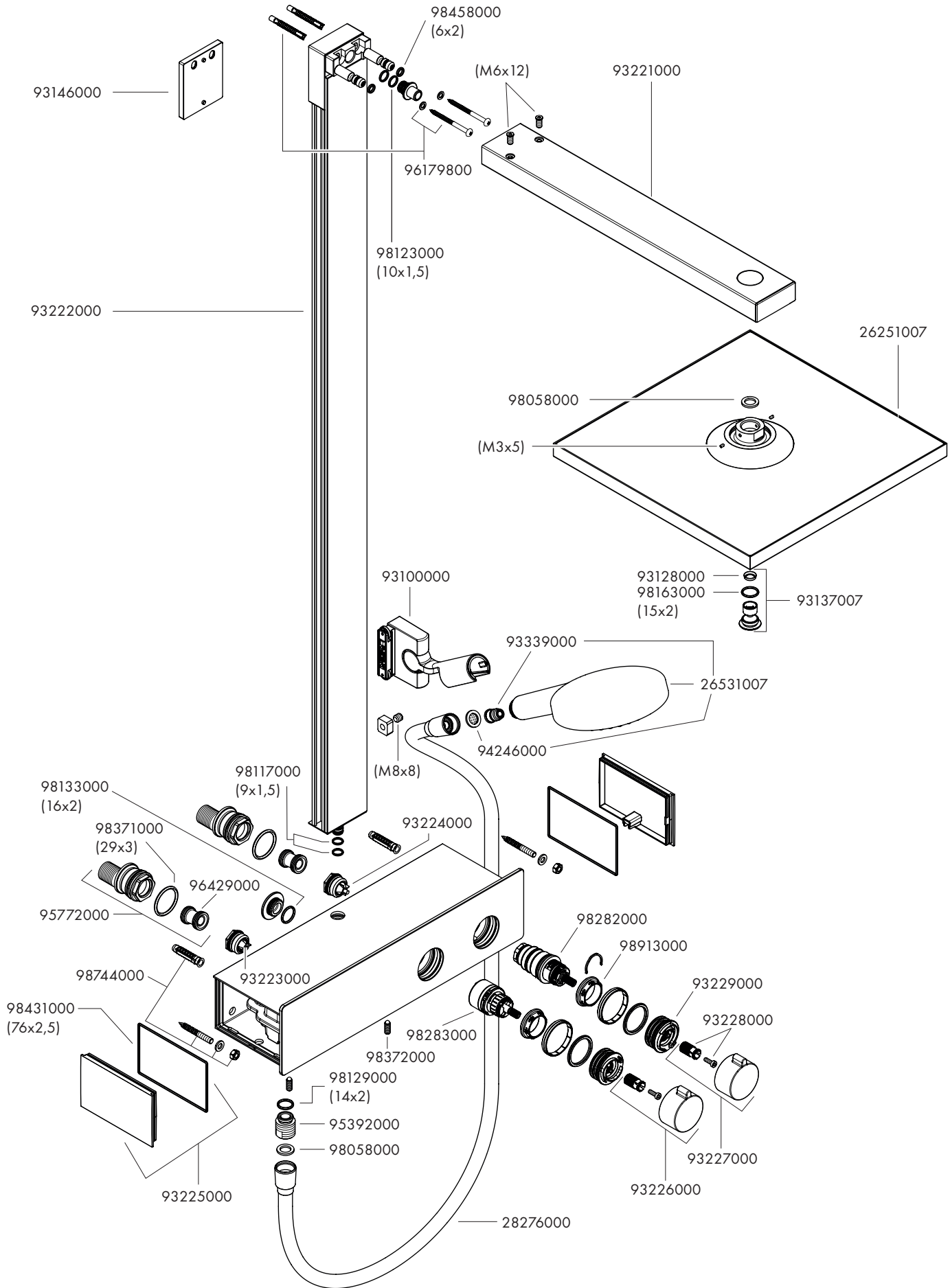



---

**hansgrohe**

Hansgrohe · Auestraße 5 – 9 · D-77761 Schiltach · Telefon +49 (0) 78 36/51-1282 · Telefax +49 (0) 7836/511440  
E-Mail: [info@hansgrohe.com](mailto:info@hansgrohe.com) · Internet: [www.hansgrohe.com](http://www.hansgrohe.com)

03/2018  
9.06095.52